

ANTIVIRAL EFFECT OF ELAETHEROCOCCUS IN EXPERIMENTAL
INFLUENZA INFECTION

S. F. Prokhorova, M. P. ZNEVY
All-Union Research Institute of Influenza, USSR Ministry of
Public Health, Leningrad

The search for acceptable substances with antiviral activity for clinical application against influenza and other viral acute respiratory diseases is carried out along the following basic lines: 1) by directed synthesis of new compounds, 2) by screening of natural substances, including those of plant origin, 3) by uncovering antiviral activity in existing preparations which have other applications in medicine.

Some interesting data on the search for substances of plant origin with broad range of nonspecific activity against influenza and other acute respiratory diseases with minimal side effects are summarized in the review by Pravedina and Kovalyeva (1979). Antiviral properties to influenza viruses were discovered in plant alkaloids from the Papaveraceae family, Chelidonium and other plants. A substance extracted from olives was found to have a wide range of antiviral activity against influenza, parainfluenza and rhinoviral infections. The high antiviral activity of glycosides from *Hydrilium perfoliatum* was demonstrated to type A influenza virus in chicken embryos and in tissue culture; viral activity was reduced by 83-100%. Antiviral activity to type B influenza virus was observed in *Helichrysum atratum*, *Salvia officinalis*, and in tannins.

Attention of investigators has been drawn to antiviral quality of preparations made from plants of the Araliaceae family, the best known of which are Ginseng and Eleutherococcus (Dardymov, 1976). At present, wide practical usage of Ginseng is not possible due to the limited resources of the plant. Therefore, Eleutherococcus preparations are preferred in research work, because they provide pronounced interferogenic and immunostimulating activity; they are similar in their effect to Ginseng preparations and in some cases produce a greater effect (Vasler, 1983; Vardymov, 1976).

We have studied the antiviral, interferogenic and immunostimulating activity of several preparations, including those of

plant origin, in experimental influenza infection.

Data on the antiviral activity of Eleutherococcus extract (EE) are presented in Fig. 1. The immunostimulator and the virus were administered simultaneously to white mice intranasally. One day after virus inoculation, no influenza virus was detected in the lungs of animals. On the second day, the titer of influenza virus reached 4.5 lg KID 50/0.2 ml in the lungs of the control group and only 1.0 lg KID 50/0.2 ml, i.e., 3.5 lg less in experimental animals.

Similar results were obtained on the third day after infection. On the fourth day, however, the virus titer was approximately the same in both groups. But a pronounced suppression of virus reproduction occurred later in the group that had received EE: on days 5 and 6 following infection, the virus titer in the lungs of control animals attained 4.24 and 4.63 lg KID 50/0.2 ml, respectively, while in the lungs of the experimental group no virus was found. Therefore, marked antiviral effect of EE was shown in experimental influenza infection of white mice.

In experiments on animals the immunostimulating activity of several preparations, including those of plant origin, was studied in their combined usage with influenza vaccine. It was shown that most of the preparations had an immunostimulating effect that manifested itself in increased survival of animals infected with lethal doses of influenza virus (Fig. 2). Since almost all the preparations induced production of endogenous interferon, we consider that the well-known immunostimulating influence of interferon on factors of cell immunity is one of the main mechanisms of their immunostimulating activity.

The increase of immunogenic activity of influenza virus vaccines by means of readily available immunostimulators of plant origin may have great importance for the protection of persons with low immunobiological reactivity. Analysis of literature data and the results of our investigations indicate the existence of a variety of mechanisms of specific and nonspecific protection by means of combined application of vaccines and plant immunostimulators. In influenza infection the stimulation of various protective mechanisms is of paramount importance in overcoming the narrow specificity of antiinfluenza postvaccinal immunity and obtaining a possibly longer effect with less amount of antiinfluenza

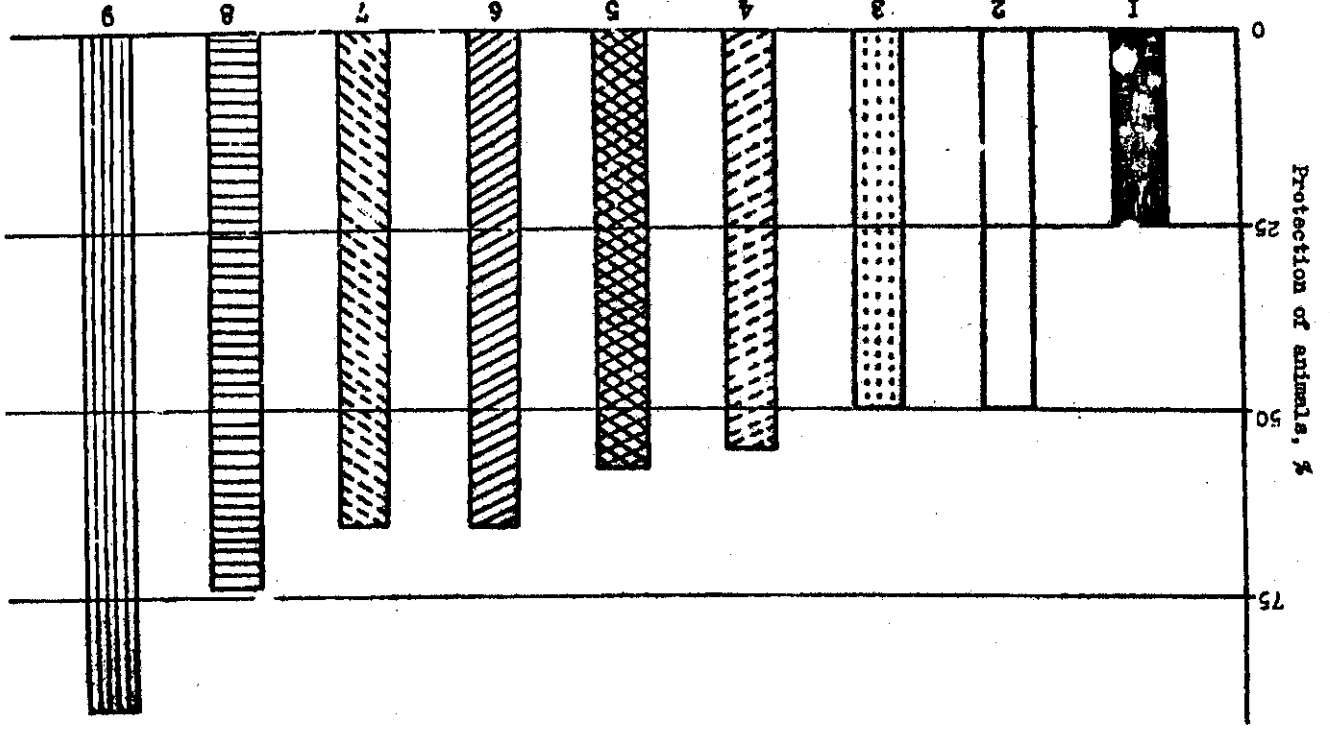

Fig. 2. Protection of white mice against influenza by means of combined application of live influenza vaccine and immunostimulators, administered in a single injection 6 days before infection with interon inducers and immunostimulators. 1 - vaccine, 2-9 - vaccine in combination

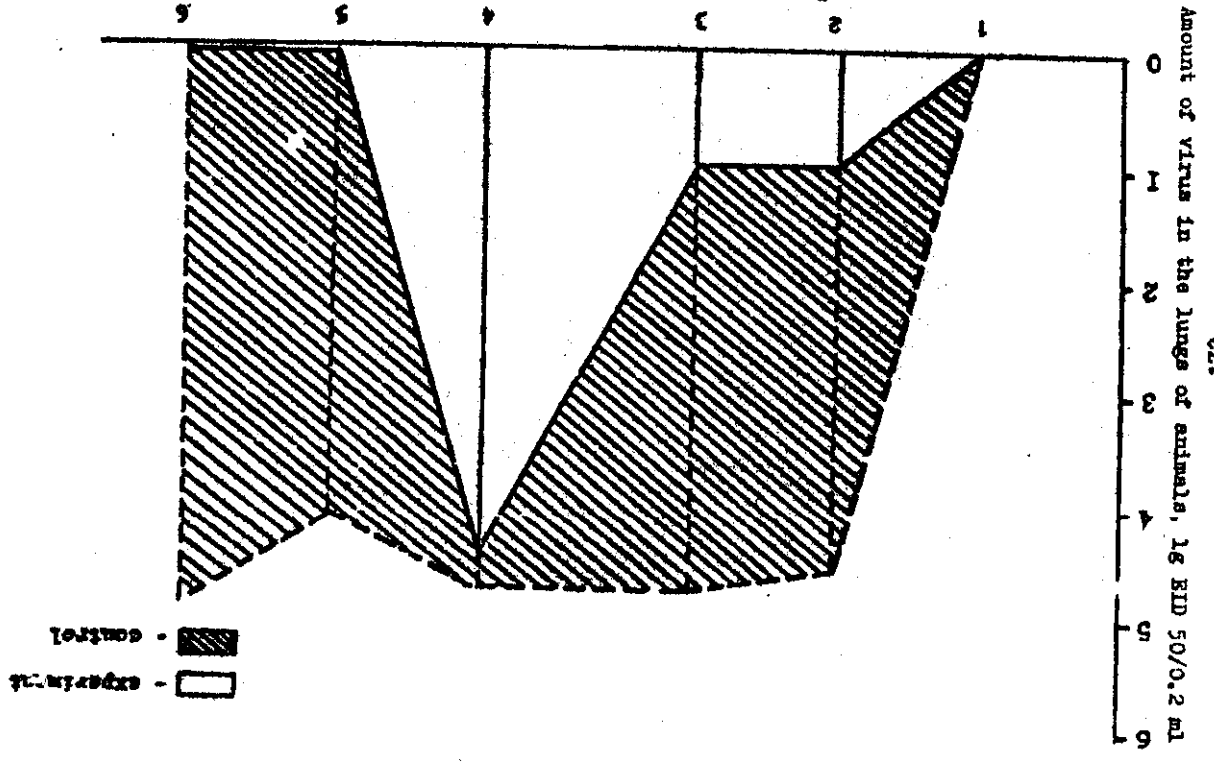

Fig. 1. Antiviral activity of ether-soluble extract in the experimental influenza infection.

antigens.

It seems to be very advantageous to use small doses of preparations obtained from high plants which are safe for human organisms and have high antiinfluenza activity. These preparations can be given with other antiviral drugs or viral vaccines.

References

Dardymov I. V. Ginseng and Kleutherococcus (Towards a Mechanism of Biological Activity). Moscow: Nauka, 1976, 184 c.

Pravdina I. B., Kovalova F. P. Propylaxis and treatment of influenza and viral ABD by drugs of plant origin. - In: *Ispolnena gramna i ostarak pashparopnykh zashchashchaniy*. Leningrad: Nauchnoe Reshenie Nauchno-Meditsinskogo Instituta gramna, 1979, t. 24, s. 135-134.

Wacker A. Über die Interferon-Induzierende und Immunstimulierende Wirkung von Kleutherococcus. - *Nahrungsmittelkunde*, 1963, Bd. 32, H. 6, S. 339-343.

ANTIALCOHOLIC EFFECT OF KLEUTHEROCOCCUS

A. B. Kulenov, M. I. Polozhentseva, V. P. Yakov
Department of Physiology and Pharmacology, Institute of
Marine Biology, Far East Science Center, USSR Academy of
Sciences, Vladivostok; Vladivostok State Medical Institute,
Vladivostok, USSR

The complex program for prophylaxis of alcoholism suggests increased offer of light nutritive alcoholic drinks. One way to decrease toxicity of alcoholic drinks, their narcotic potential and the tendency to be habit-forming is likely to be associated with splitting of strong alcoholic drinks with some complexers or biologically active agents of natural origin with a pronounced antialcoholic effect. In Eastern medicine, the introduction of Ginseng roots into alcohol is believed to have an antialcoholic effect decreasing the toxicity of ethanol (Brekman, 1976). It was shown that Kleutherococcus extract (EK) exerts an antitoxic effect and eliminates the narcotic effect of alcohol *in vitro* (Basselzov, 1963). This effect of Kleutherococcus extract was corroborated also in embryotoxicological experiments (Brekman et al., 1982). When introduced simultaneously with ethanol to rats in various periods of gestation, EK decreased 2-2.5 times embryo mortality caused by ethanol. A prophylactic Kleutherococcus treatment for 14 days prior to pregnancy practically wholly protected fetuses against ethanol impact during organogenesis.

The ability of the preparation to reduce toxic alcoholic manifestations in rats in different stages of organogenesis created an opportunity to study EK effect upon the habit-forming process, to evaluate the level of ethanol consumption in experiment and to estimate the possibility of using this preparation for prophylaxis and treatment of alcoholism.

Material and Methods

Male Wistar rats (995 animals) with an initial weight of 140-150 g were used in the experiment. The antialcoholic effect of EK, a possible ability to prevent and eliminate pathological addiction to alcohol, to decrease alcohol consumption and to treat alcoholic intoxication were studied in experimental models of active and passive alcoholism. We used a model of free choice between alcohol and water (Barov, Buzkov, 1964). The animals

which had been preliminarily selected as preferring alcohol received alcohol for 1, 2, 3, and 6 months. In the control group, 15, 20 and 30 % alcohol was given. The test animals were given alcohol with EE (2 ml/100 ml alcohol). To obtain identical orogenicoleptic symptoms of alcoholic intoxication, additional experiments were conducted in the control and test groups with intragastral introduction of EE (0.1 ml/100 g body weight), alcohol was given using the routine scheme. The experiments studied the dynamics of the level and rate of alcohol consumption, characteristics of alcohol motivation during the deprivation period and with additional stressful impact on the animals. At the end of the experiment, the animals were decapitated and their organs were examined for morphological and histological changes.

Clinical studies were carried out in the Narcological Clinics of Psychopathological Hospital in Vladivostok. The EE was given to patients suffering from chronic alcoholism of the 2nd stage and receiving treatment in the clinic. An aqueous solution of EE (equivalent to 2 ml aqueous-alcohol extract) was given to the patients once a day for 3 months. The control group received "placebo", a solution of an identical taste and colour. The method of double blind control was used in the experiment. The EE and "placebo" were administered in complex with a generally accepted therapeutic treatment against chronic alcoholism (desintoxication, amorphino-antabus treatment, psychotherapy etc.). The main criterion of the efficiency of the treatment with the preparation was the frequency and clinical picture of recurrences of alcoholic addiction. The cases of absolute and complete abstinence from alcohol were recorded as cases of positive results of the treatment. The cases of drinking after the treatment, including also a single event, were treated as a recurrence.

Results and Discussion

During a 6-month experiment with a free choice between alcohol and water, the test rats consumed 20 % alcohol by 62.3 % less and 30 % alcohol with EE by 68.5 % less than an average monthly value for the control group (Fig. 1). The Kleutheroococcus effect upon the rate of alcohol consumption by rats did not depend upon the way of introduction of the preparation. In the experiment series, where EE was administered daily intragastral-

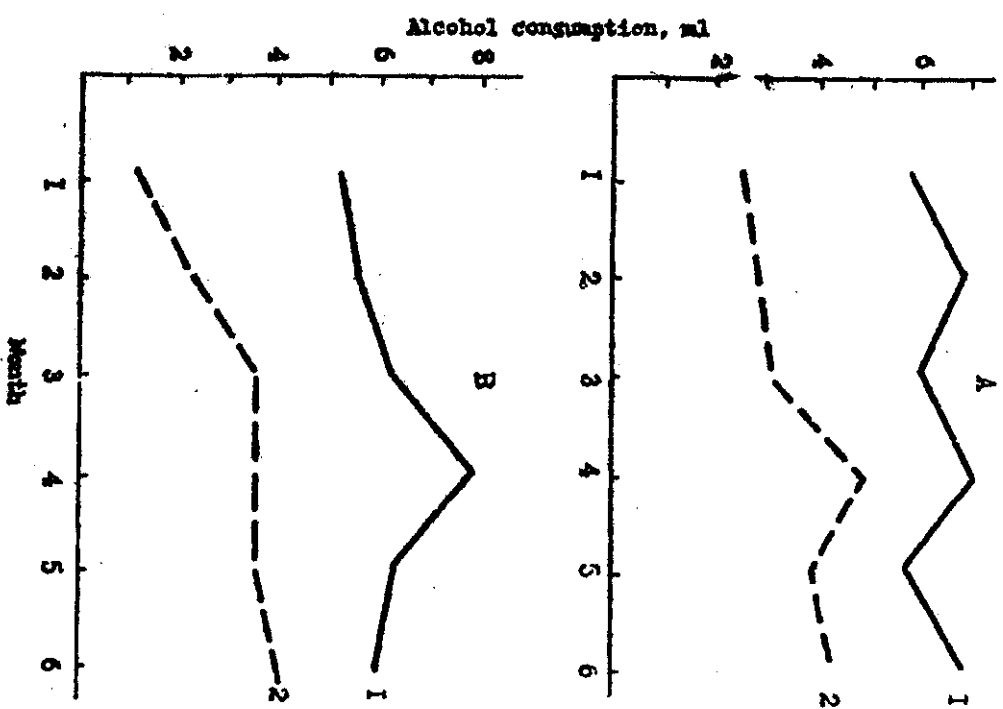

Fig. 1. Dynamics of the mean daily consumption of alcohol at free choice during 6 months. A, 1 - the control group (20 % alcohol for drinking); 2 - the test group (20 % alcohol + 2 ml Kleutheroococcus per 100 ml alcohol for drinking); B, 1 - the control group (30 % alcohol for drinking); 2 - the test group (30 % alcohol + 2 ml Kleutheroococcus per 100 ml alcohol for drinking).

ly (test group), 12 months was significantly received intragastrically

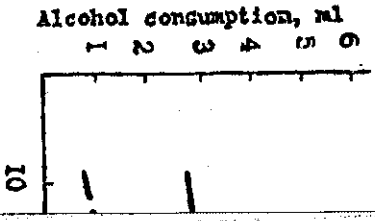
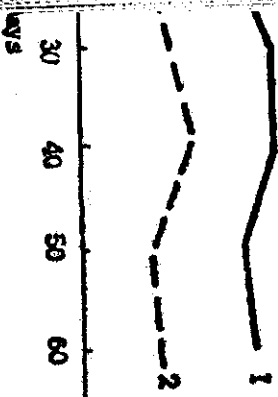

Fig. 2. Dynamics of free choice during 10 days of drinking, daily per 100 g body weight; drinking, daily in per 100 g body weight

EE added to 20% alcohol motivation during 20% alcohol alcohol for one week were again given at (test group). A decrease in alcohol consumption the rate after deprivation period was similar to the control group, the contrary, the alcohol than before group (Table 1).

alcoholic consumption during two months in the control group, which by the same substance (Fig. 2).



an daily consumption of alcohol at 1 - the control group (30% alcohol and injection of 0.1 ml pure water the test group (30% alcohol for injection of 0.1 ml Eleutherococcus

2 ml/100 ml ethanol) decreased alcohol. After three months of deprivation and control rats were deprived of the deprivation period, the rates (test group) and alcohol with EE the background rates of daily alcohol last week before deprivation and showed that in the test group the decrease by an increase in alcohol consumption. In the control group, on and after deprivation 10% more alcohol and 34% more than in the test

Table 1
Effect of Eleutherococcus extract upon the rate of daily consumption of 20% alcohol in rats under conditions of free choice and alcoholic motivation

Test period, duration in weeks	The rate of consumption of 20% alcohol, ml/kg	
	Control	Eleutherococcus
1	7.0 ± 1.06	8.1 ± 0.68
2	10.0 ± 1.11	10.3 ± 1.01
3	10.9 ± 1.96	11.7 ± 1.24
4	22.8 ± 2.37	11.1 ± 0.80*
5	22.7 ± 2.30	10.3 ± 0.90*
6	15.6 ± 1.02	11.1 ± 0.80*
7	11.1 ± 1.33	10.8 ± 0.70
8	11.6 ± 0.23	8.8 ± 1.02*
9	11.8 ± 0.23	5.4 ± 0.44*
10	9.8 ± 0.60	7.1 ± 0.41*
11	7.4 ± 1.30	5.4 ± 0.56
12	7.8 ± 0.81	7.1 ± 0.33
13		Deprivation
14	9.8 ± 0.43	6.5 ± 0.41*

*p < 0.01

More striking results were obtained in the model of alcohol-nation of animals under stress conditions with a free choice between 15% alcohol and pure water. It is known for animals that stress impact leads to a sharp rise in alcohol consumption and to an increased number of "drinking" animals (Durov, Zinkov, 1984). An additional chronic stress was simulated in animals by overcrowded maintenance. The rats were divided into groups with normal conditions of maintenance (4 animals in a cage) and group with overcrowded maintenance (16 animals in a cage), the scheme of offering liquids being the same. The rate of the control group with overcrowded maintenance sharply increased alcohol consumption (Fig. 3). During a month, daily consumption of 15% alcohol

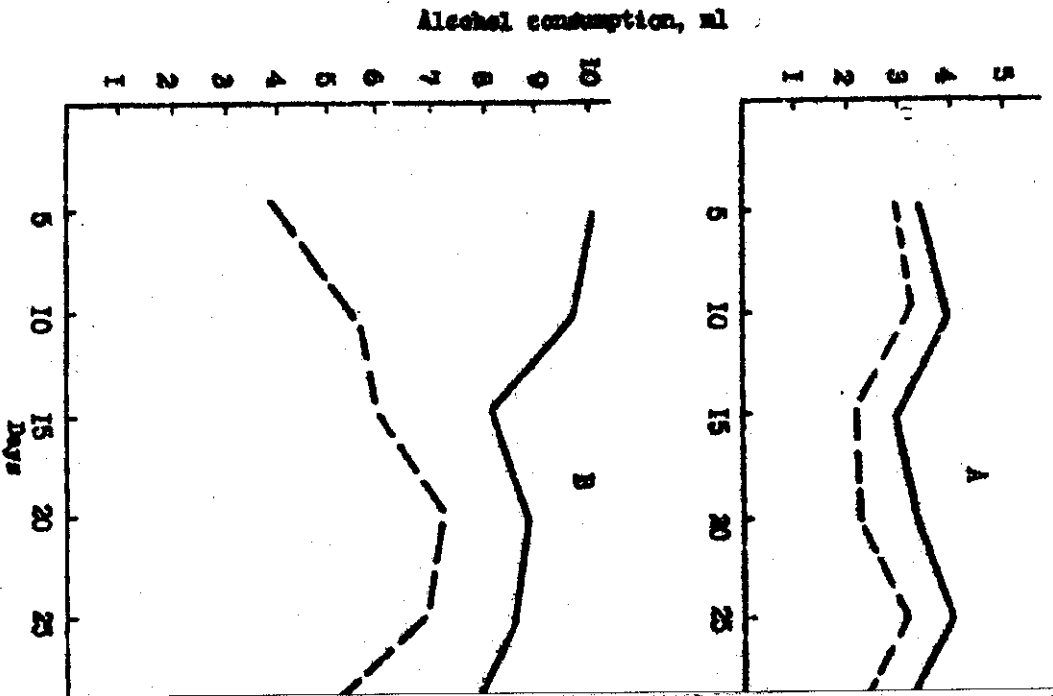

Fig. 3. Effect of Klauterococcus upon the mean consumption of 15 % alcohol at free choice under additive or impact (overexposure) on rats. A. 1 - the control group (normal maintenance); 2 - the test group (15 % alcohol). B. 1 - the control group at normal maintenance; 2 - the test group at overexposure.

180

is a range of 40-50 ml/kg body weight, and under normal conditions the value ranged within 14-18 ml/kg body weight, which is 70 % less than in the group of additionally stressed animals. Overexposed maintenance also alcoholic motivation in the test group, and alcohol consumption rose by 56 % (28 ml/kg body weight on the average). However, total consumption of alcohol in the test group with additional motivation was 40 % less than in the control.

We tried to explain the obtained pharmacological effect of EB, responsible for decreased alcoholic intoxication, a lower alcohol consumption at free choice between alcohol and water and on the background of additional alcoholic motivation, with a direct interaction of the preparation and the benzene ethanol-oxidizing system. In experiments by Ylyg and Ylyg, Klauterococcus did not significantly change the ADH activity. Probably, the antialcoholic effect of EB is based on some more general mechanisms. It is known that the sympatho-adrenal system, involved in the processes connected with chronic alcoholic intoxication is an important link of pathophysiological basis of formation of alcoholic dependence. Activation of the system by the products of metabolism of alcohol and production of an alcohol-like compound play an important part in development of this pathological state (Shoberg, Tibson, 1978). Chronic alcoholism initially causes an intensive production of catecholamines leads further to a decrease in their level and to depletion of the hypothalamo-adrenal functional interaction. Moreover, atrophy of both cortical and medullar layers of adrenals were observed (Pyatitskaya, 1975). Similar results were also obtained in our 6-month experiment on active alcoholism of animals. With EB added to alcohol, depletion of adrenals was less pronounced, which agrees perfectly with a well-known mechanism of the preparation effect (Dagynov, 1976). It is likely that EB promotes the maintenance of adequate metabolic processes under toxic stress and reduced the adrenergic and hormonal "pressure" during frequent drinking.

On the basis of the obtained results on anti-alcoholic effect of Klauterococcus and on the clinical practice of treatment of several somatic diseases with preparation, we tried the preparation in the complex anti-recurrence therapy of chronic alcoholism.

181

holics. The "risk" groups, i.e. the B

Table 2

Effect of Klentherococcus therapy of chronic

Clinical character

Total number of patients
Average age
Risk-factor
Recurrences
Of them:
Recurrence within 1
Repeated recurrence
Repeated compulsory
treatment in clinic
Secondary acute
psychosis

Note. In addition patients of the test 2 ml daily for 3 mo

A positive effect of the test group and important indication of alcohol and pronounced (10%) for the test. The number of cases 0 for the test group administration of Klentherococcus gave alcoholic adaptation.

the same in both test and control clinically identical (Table 2).

extract in complex anti-recurrence

Test	Control
75	73
32.2 years	31.8 years
6 pers.	6 pers.
20 (26.6%)	22 (30.1%)
4 (20%)	7 (31.5%)
2 (10%)	9 (40.5%)
0	4 (18.0%)
0	2 (9.0%)

Generally accepted treatment, the received Klentherococcus extract, control group received "placebo".

was obtained in 55 patients of the test group. An important indication of alcohol and pronounced (40.5%) for the control group. Repeated compulsory treatment was 0% for the control group. Thus, the anti-recurrence therapy of chronic alcoholism revealed in the wider absence of cases of social dis-

References

Brakman I. I. New and biologically active substances. Doklady: Nauka, 1976. 112 c.
Brakman I. I., Gerdelenk T. K., Dolanov A. B. Effect of Klentherococcus upon embryonic effects of ethanol. - Bulletin of the Department of Neurology and Psychiatry, 1982, p. 4, c. 52-57.
Borov Yu. V., Zolotov T. M. Biological models of chronic alcoholism. - In: Proceedings of the 10th International Conference on Alcoholism, 1984, p. 13, c. 77-88.
Bardakov I. V. Otkrytie Klentherococcus (Poznaniye o mekhanizme biologicheskoy aktivnosti). Moscow: Nauka, 1976. 184 c.
Pryutitskiy I. M. Otkrytie klentherococcus. Kazanskaya: Kazanskaya, 1976. 333 c.
Bardakov V. A. Protective effect of liquid extract of Klentherococcus roots in intoxication with ethyl alcohol. - In: Trudy Kazanskogo IV nauchnogo otdeleniya kompleksnogo Kazanskogo gosudarstvennogo nauchnogo tsentra. Kazanskaya, 1983, c. 36-37.
Shabrov E. I., Ibrimov R. E. Biochemical aspects of alcoholism. - Kazansko-frantsuzskiy zhurnal, 1978, p. 7, c. 3-14.